

Specification of MEMS Microphone (RoHS Compliance & Halogen Free)

Customer Name :

Customer Model :

Goermicro Model: S18OB381-046

Goermicro		CUSTOMER APPROVAL
<u>DESIGN</u>	<u>Yilse</u> 2021.12.15	
<u>CHKD</u>	<u>Lein</u> 2021.12.15	
<u>STANDARD</u>	<u>Angela</u> 2021.12.15	
<u>APVD</u>	<u>Roy</u> 2021.12.15	

Tel : + 86 536 3051234

E- Mail : Goermicro@Goermicro.com

Website: <http://www.Goermicro.com>

Address: No.268 Dongfang Road, High-Tech Industry
Development District, Weifang, Shandong, P.R.C.

Contents

1	Introduction	4
2	Test Condition	4
3	Electrical Characteristics	4
3.1	Standard Mode	4
3.2	Low Power Mode	5
4	Frequency Response Curve	5
5	Measurement Circuit	6
6	Test Setup Drawing	6
7	Mechanical Characteristics	7
7.1	Appearance Drawing	7
7.2	Weight	7
8	Reliability Test	8
8.1	Vibration Test	8
8.2	Drop Test	8
8.3	Temperature Test	8
8.4	Humidity Test	8
8.5	Mechanical Shock Test	8
8.6	Thermal Shock Test	8
8.7	Reflow Test	8
8.8	Electrostatic Discharge Test	8
9	Package	9
9.1	Tape Specification	9
9.2	Reel Dimension	10
9.3	The Content of Box	10
9.4	Packing Explain	11
10	Storage and Transportation	11
11	Land Pattern Recommendation	12
11.1	The Pattern of MIC Pad	12
11.2	Recommended Soldering Surface Land Pattern	12
12	Soldering Recommendation	13
12.1	Soldering Machine Condition	13
12.2	The Drawing and Dimension of Nozzle	13
12.3	Reflow Profile	14
12.4	Rework	15
13	Cautions	15
13.1	Board Wash Restrictions	15
13.2	Nozzle Restrictions	15
13.3	Blowing Restrictions	15
13.4	Ultrasonic Restrictions	15
13.5	Case Adaption to Pressure Restrictions	15
14	Output Inspection Standard	15

1 Introduction

MEMS MIC which is able to endure reflow temperature up to 260°C for 50 seconds can be used in SMT process. It is widely used in telecommunication and electronics device such as mobile phone, MP3, PDAs etc.

2 Test Condition ($V_{DD}=2.7V/1.6V$, $L=50cm$)

Standard Conditions (As IEC 60268-4)	Temperature	Humidity	Air pressure
Environment Conditions	+15°C ~ +35°C	25% R.H. ~ 75% R.H.	86kPa ~ 106kPa
Basic Test Conditions	+20°C ± 2°C	60% R.H. ~ 70% R.H.	86kPa ~ 106kPa

3 Acoustic and Electrical Characteristics

3.1 Standard Mode

(Test Condition: $V_{DD}=2.3V\sim 3V$)

Item	Symbol	Test Conditions	Min	Typ	Max	Unit
Sensitivity	S	f=1kHz, Pin=1pa	-39	-38	-37	dB
Output Impedance	Zout	f=1kHz, Pin=1pa			400	Ω
Directivity	D(θ)	Omnidirectional				
Current Consumption	I	Operating Voltage Range	100		200	μA
S/N Ratio	S/N(A)	f=1kHz, Pin=1Pa A-Weighted Curve	69	70		dB
Power Supply Rejection	PSR	Measured with 217Hz, 100mVpp square wave		-106		dB
Decreasing Voltage Characteristic	ΔS	f=1kHz, Pin=1Pa Vs=3.0 --2.3V	No Change			dB
Operating Voltage Range	Vs		2.3	2.7	3.0	V
Total Harmonic Distortion	THD	94dB SPL@1 kHz		0.2	0.5	%
Acoustic Overload Point	AOP	10% THD @1 kHz		137		dB SPL
		10% THD @50Hz		132		dB SPL
Load Resistor	RL		25			kΩ
Load Capacitance	CL				150	pF
VDD ramp up time	tVDDup	VDD reaches its final value within +/- 10 % tolerance	0.001		5	ms
Corner Frequency	LFRO			45		Hz
Phase Response	PR	f=50Hz	-6		6	°
		f=100Hz	-5		5	°
		f=5000Hz	-5		5	°

3.2 Low Power Mode

(Test Condition: $V_{DD}=1.5V\sim 1.9V$)

Item	Symbol	Test Conditions	Min	Typ	Max	Unit
Operating Voltage Range	V_{DD}		1.5	1.6	1.9	V
Current Consumption	I	$V_{DD}=1.6V$			80	μA
Sensitivity	S	$f=1kHz, P_{in}=1Pa$	-39	-38	-37	dB
S/N Ratio	SNR	$f=1kHz, P_{in}=1Pa$ A-Weighted Curve		68.5		dB
Total Harmonic Distortion	THD	110dB SPL@ $f=1kHz$			1	%
Acoustic Overload Point	AOP	10%THD@1kHz		132		dB SPL
		10% THD @50Hz		132		dB SPL
Power Supply Rejection	PSR	100mVpp square wave@217Hz, $V_{DD}=1.6V$ A-Weighted		-106		dBV
Power Supply Rejection Ratio	PSRR	200mVpp sine wave@1kHz, $V_{DD}=1.6V, R_{load}>2k\Omega$		88		dB
Output Impedance	Z_{out}	$f=1kHz, P_{in}=1Pa$			400	Ω
Decreasing Voltage Characteristic	ΔS	$f=1kHz, P_{in}=1Pa$ $V_{DD}=1.9 \sim 1.5V$	No Change			dB
Directivity	$D(\theta)$	Omnidirectional				
Phase Response	PR	$f=50Hz$	-6		6	$^{\circ}$
		$f=100Hz$	-5		5	$^{\circ}$
		$f=5000Hz$	-5		5	$^{\circ}$

4 Frequency Response Curve and Limits

Typical Free Field Response
Normalized to 1kHz Standard Mode

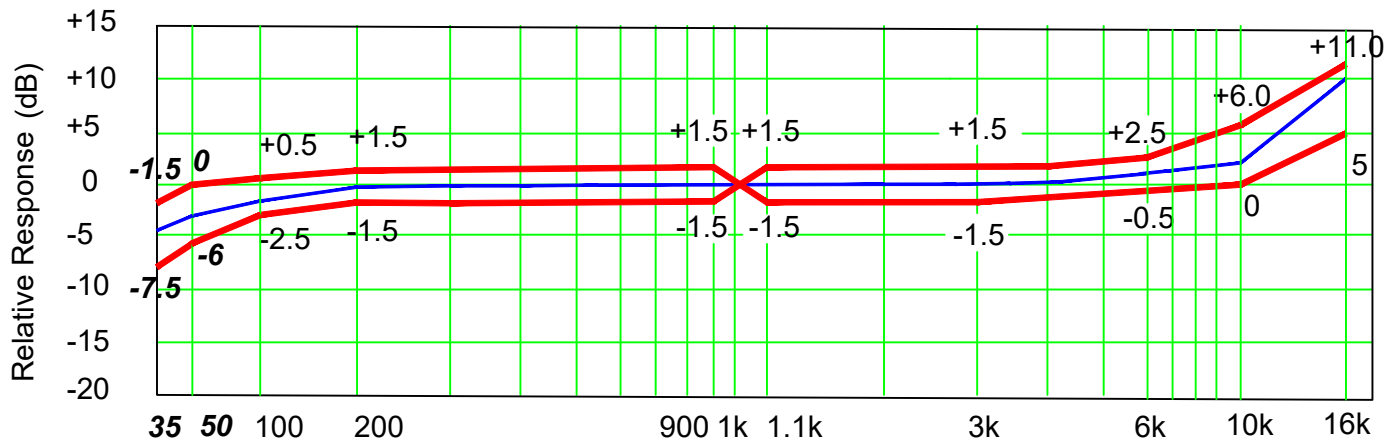

Typical Free Field Response
Normalized to 1kHz Low Power Mode

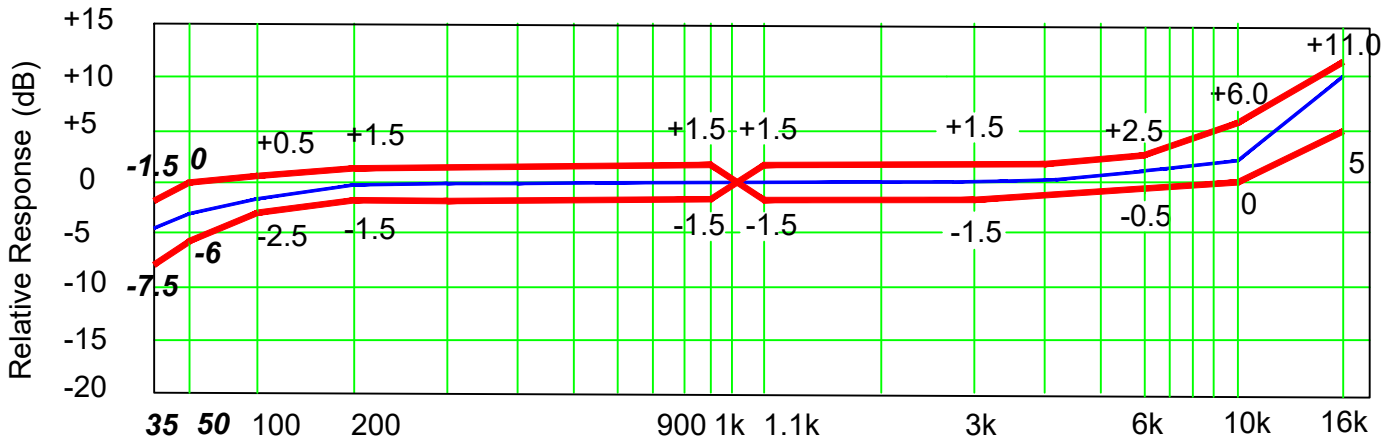

5 Measurement Circuit

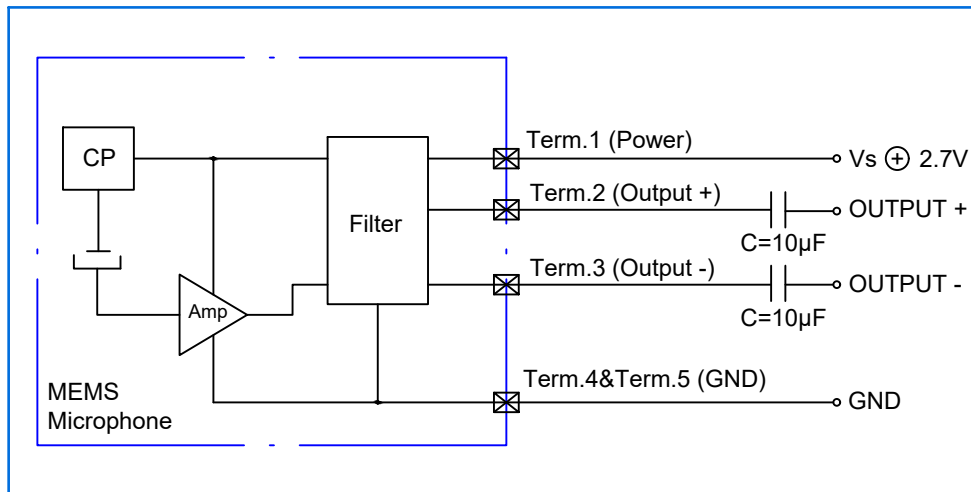

6 Test Setup Drawing

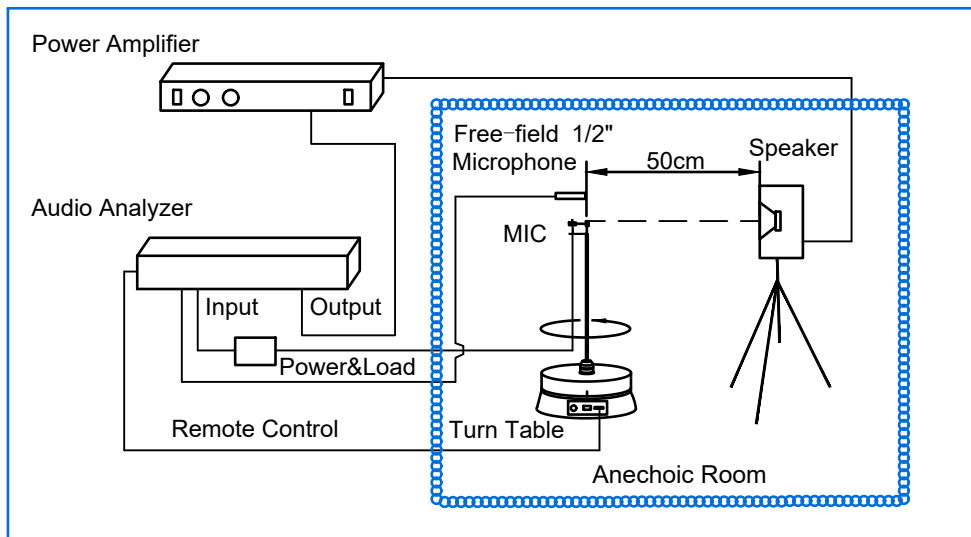

7 Mechanical Characteristics

7.1 Appearance Drawing (Unit: mm)

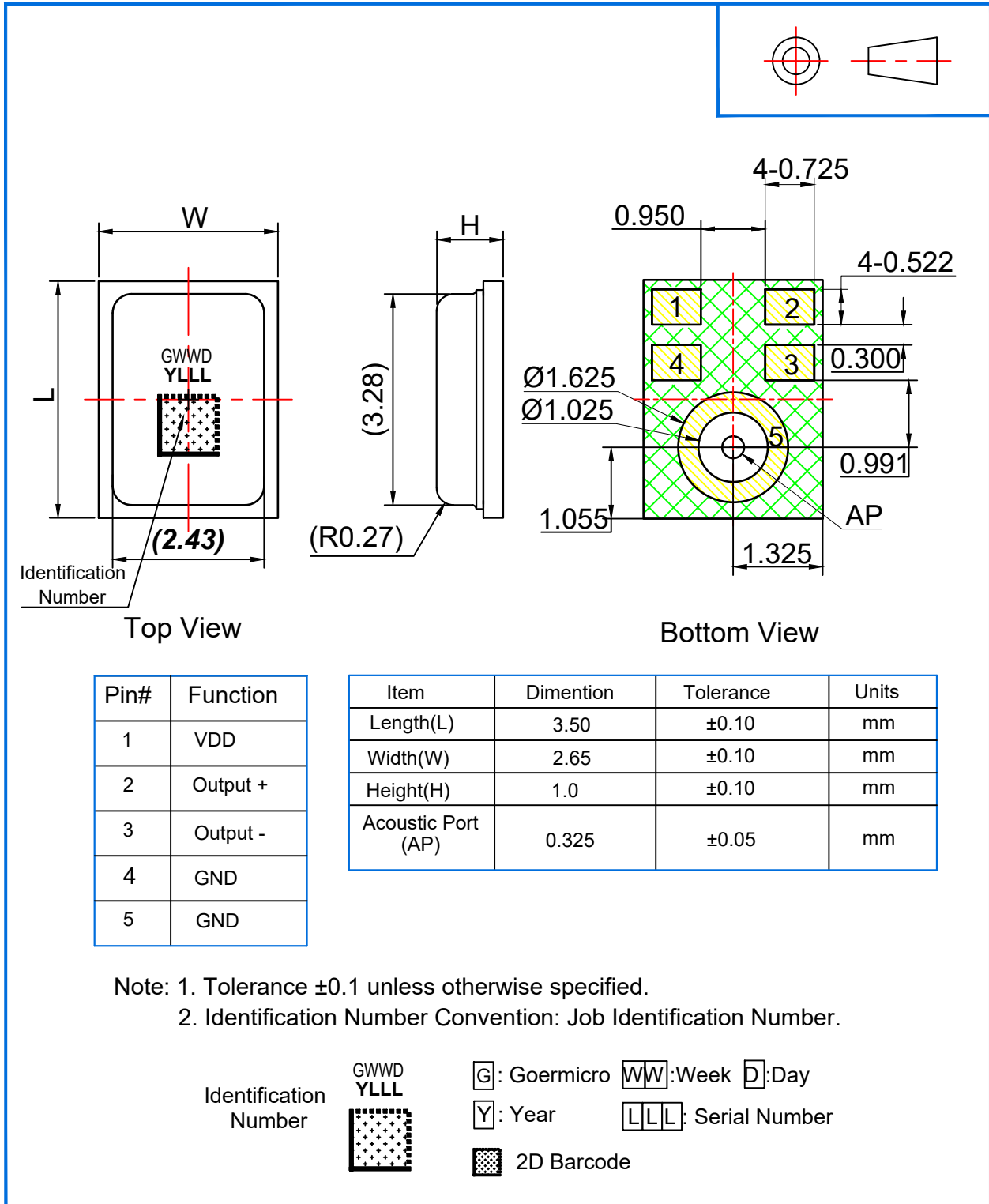

7.2 Weight

The weight of the MIC is Less than 0.04g.

8 Reliability Test

<p>8.1 Vibration Test</p>	<p>To be no interference in operation after vibrations, 4 cycles, from 20 to 2,000Hz in each direction(X,Y,Z), 48 minutes, using peak acceleration of 20g, sensitivity should vary within $\pm 3\text{dB}$ from initial sensitivity. (The measurement to be done after 2 hours of condition at 15°C-35°C, R.H. 25%~75%)</p>
<p>8.2 Drop Test</p>	<p>To be no interference in operation after dropped to 1.0cm steel plate 12 times from 1.5 meter height in state of JIG,JIG weight of 100g, sensitivity should vary within $\pm 3\text{dB}$ from initial sensitivity. (The measurement to be done after 2 hours of condition at 15°C-35°C, R.H. 25%~75%)</p>
<p>8.3 Temperature Test</p>	<p>a) After exposure at $+125^{\circ}\text{C}$ for 200 hours, sensitivity should vary within $\pm 3\text{dB}$ from initial sensitivity. (The measurement to be done after 2 hours of condition at 15°C-35°C, R.H. 25%~75%) b) After exposure at -40°C for 200 hours, sensitivity should vary within $\pm 3\text{dB}$ from initial sensitivity. (The measurement to be done after 2 hours of condition at 15°C-35°C, R.H. 25%~75%)</p>
<p>8.4 Humidity Test</p>	<p>After exposure at $+85^{\circ}\text{C}$ and 85% relative humidity for 200 hours, sensitivity should vary within $\pm 3\text{dB}$ from initial sensitivity. (The measurement to be done after 2 hours of condition at 15°C-35°C, R.H. 25%~75%)</p>
<p>8.5 Mechanical Shock Test</p>	<p>Then subject samples to three one-half sine shock pulses (3000 g for 0.3 milliseconds) in each direction (for six axes in total) along each of the three mutually perpendicular axes for a total of 18 shocks, sensitivity should vary within $\pm 3\text{dB}$ from initial sensitivity. (The measurement to be done after 2 hours of condition at 15°C-35°C, R.H. 25%~75%)</p>
<p>8.6 Thermal Shock Test</p>	<p>After exposure at -40°C for 30 minutes, at $+125^{\circ}\text{C}$ for 30 minutes (change time 20 seconds) 32 cycles, sensitivity should vary within $\pm 3\text{dB}$ from initial sensitivity. (The measurement to be done after 2 hours of condition at 15°C-35°C, R.H. 25%~75%)</p>
<p>8.7 Reflow Test</p>	<p>Adopt the reflow curve of item 12.3, after three reflows, sensitivity should vary within $\pm 2\text{dB}$ from initial sensitivity. (The measurement to be done after 2 hours of condition at 15°C-35°C, R.H. 25%~75%)</p>
<p>8.8 Electrostatic Discharge Test</p>	<p>Under $C=150\text{pF}$, $R=330\text{ohm}$. Tested to $\pm 8\text{KV}$ contact to the case and tested to $\pm 2\text{kV}$ contact to I/O terminals.10 times. Grounding. Sensitivity should vary within $\pm 3\text{dB}$ from initial sensitivity. (The measurement to be done after 2 hours of conditioning at $+15^{\circ}\text{C}$~$+35^{\circ}\text{C}$, R.H.25%~75%)</p>

9 Package

9.1 Tape Specification

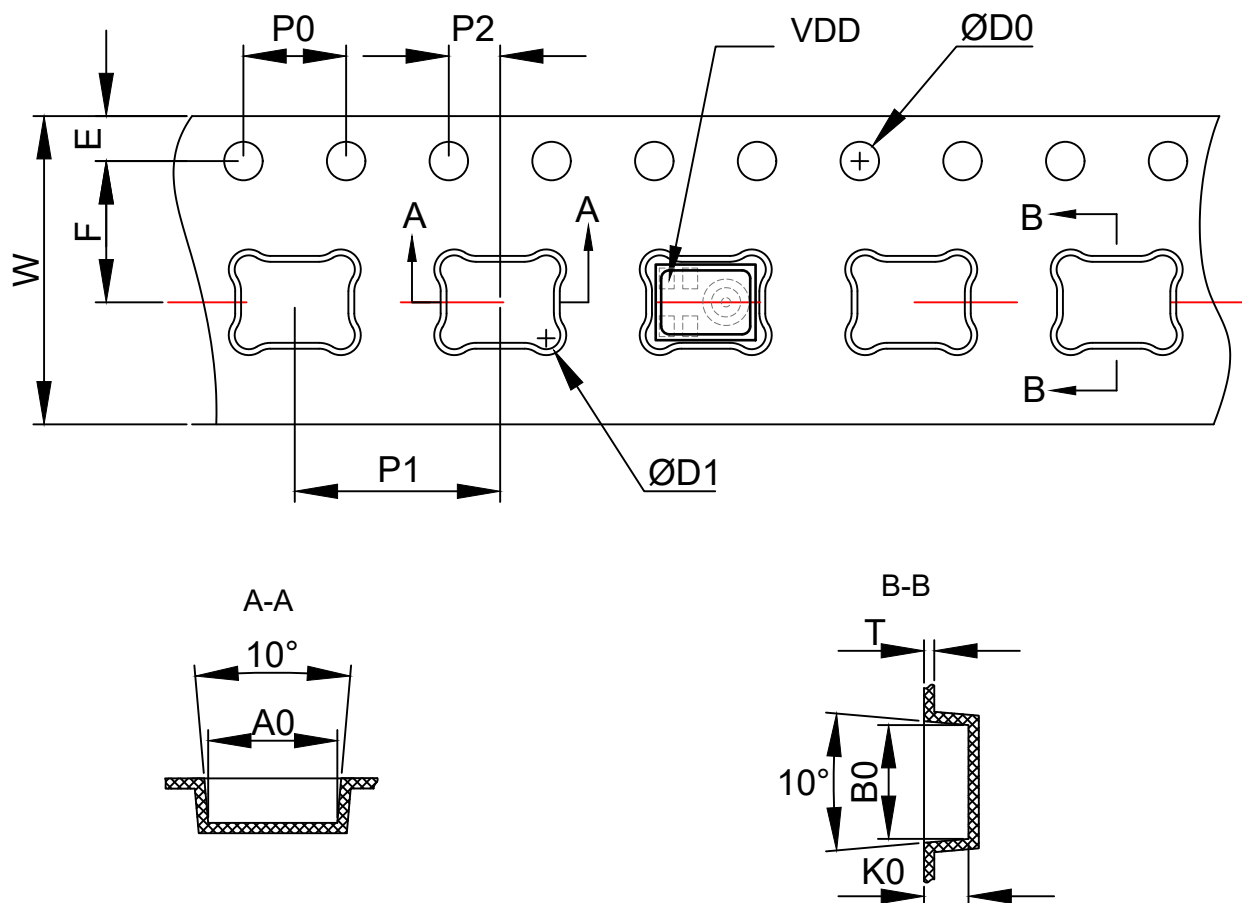

The Dimensions as Follows:

ITEM	W	E	F	ØD0	ØD1
DIM(mm)	12.0±0.30	1.75±0.10	5.5±0.05	1.50 ^{+0.10} ₀	0.50±0.10
ITEM	P0	10P0	P1	A0	B0
DIM(mm)	4.00±0.10	40.00±0.20	8.00±0.10	3.75±0.05	2.85±0.05
ITEM	K0	P2	T		
DIM(mm)	1.30±0.10	2.00±0.05	0.30±0.05		

9.2 Reel Dimension

7" reel for sample stage

13" reel will be provided for the mass production stage

The following is 13" reel dimensions (unit:mm)

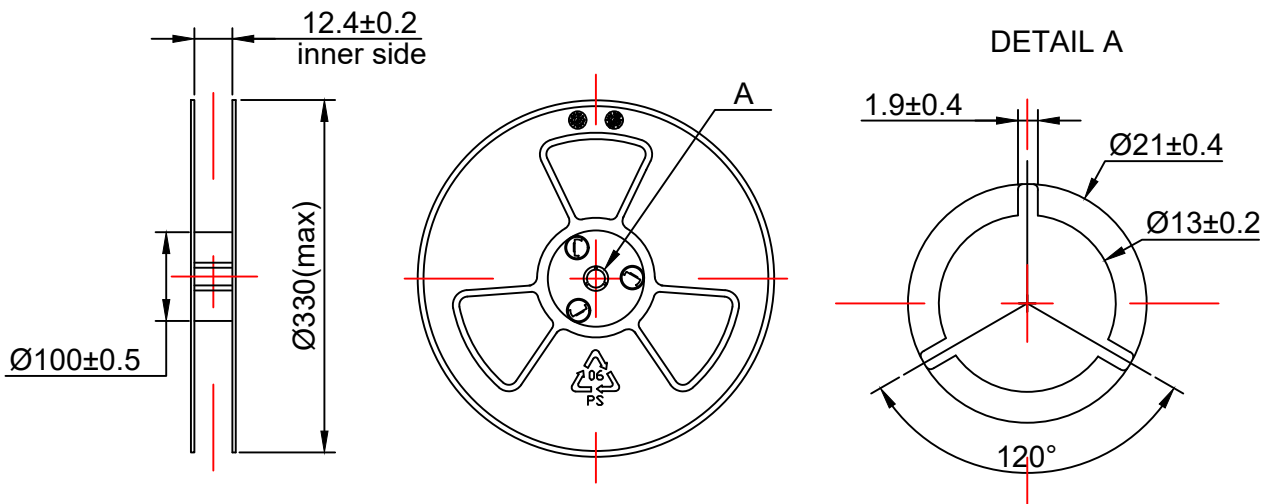

9.3 The Content of Box(13" reel)

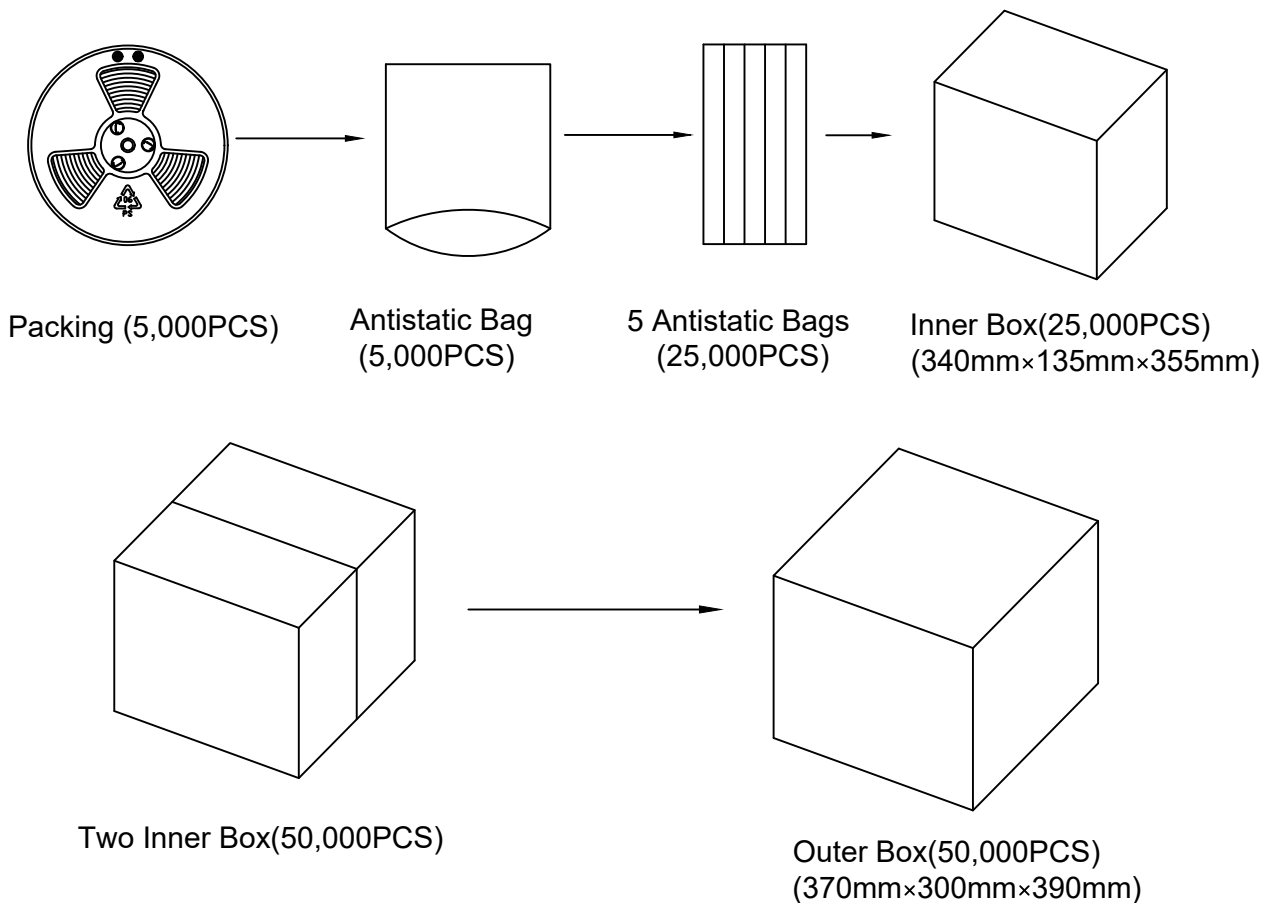

9.4 Packing Explain

9.4.1 The Label Content of the Reel

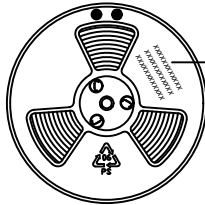

The Content Includes:
Product type, Lot, Customer P/N;
and other essential information such as
Quantity, Date etc.

9.4.2 The RoHS Label

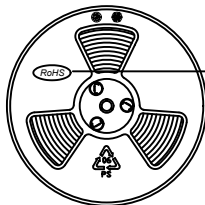

RoHS HF
Compliance Mark

10 Storage and Transportation

- 10.1 Keep MEMS MIC in warehouse with less than 75% humidity and without sudden temperature change, acid air, any other harmful air or strong magnetic field. Recommend storage period no more than 1 year and floor life(out of bag) at factory no more than 4 weeks.
- 10.2 The MEMS MIC with normal pack can be transported by ordinary conveyances. Please protect products against moist, shock, sunburn and pressure during transportation.
- 10.3 Storage Temperature Range: $-40^{\circ}\text{C} \sim +70^{\circ}\text{C}$
- 10.4 Operating Temperature Range: $-40^{\circ}\text{C} \sim +100^{\circ}\text{C}$

11 Land Pattern Recommendation

11.1 The Pattern of MIC Pad(Unit:mm)

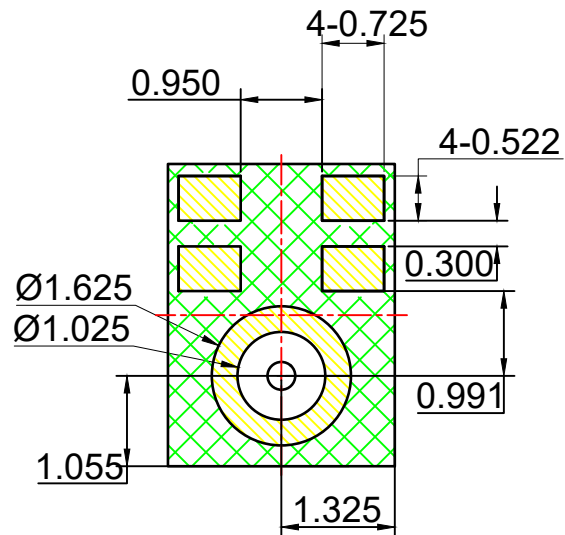

11.2 Recommended Soldering Surface Land Pattern

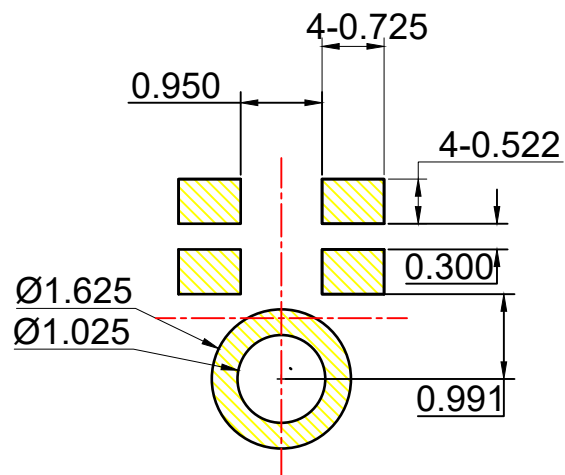

12 Soldering Recommendation

12.1 Soldering Machine Condition

Temperature Control	8 zones
Heater Type	Hot Air
Solder Type	Lead-free

12.2 The Drawing and Dimension of Nozzle

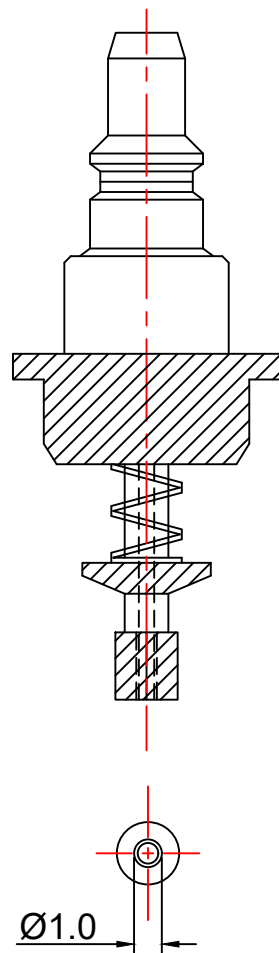

Nozzle Diameter: Ø1.0mm;
Please don't blow the acoustic port directly.

12.3 Reflow Profile

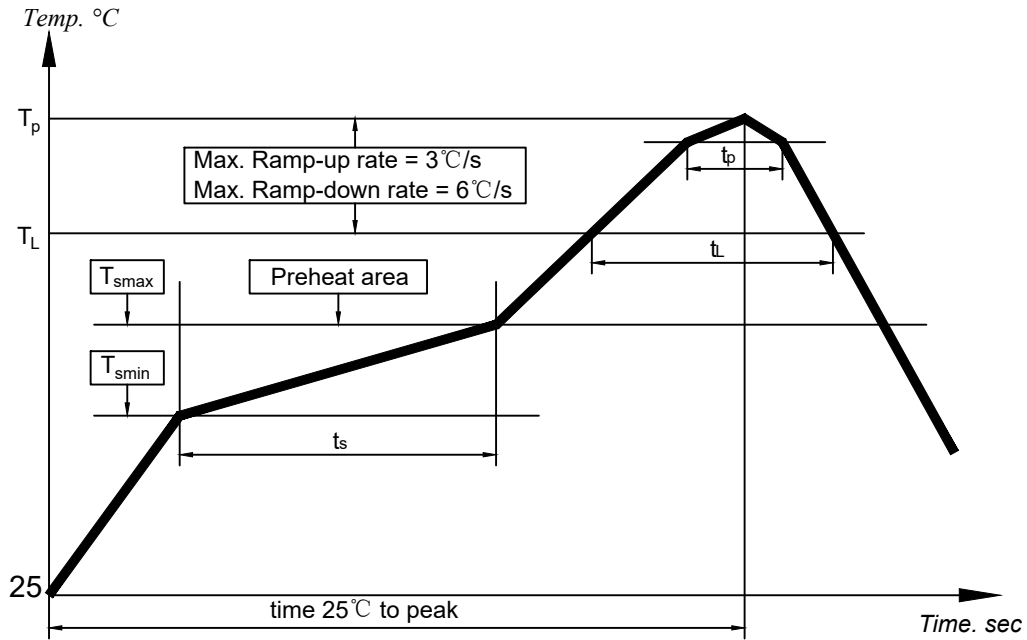

Key Features of The Profile:

Average Ramp-up rate(T_{smax} to T_p)	3°C/s max.
Preheat : Temperature Min(T_{smin}) Temperature Max(T_{smax}) Time(T_{smin} to T_{smax})(t_s)	150°C 200°C 60~180s
Time maintained above : Temperature(T_L) Time(t_L)	217°C 60~150s
Peak Temperature(T_p)	260°C
Time within 5°C of actual Peak Temperature(t_p) :	30~40s
Ramp-down rate(T_p to T_{smax})	6°C/s max
Time 25°C to Peak Temperature	8min max

When MEMS MIC is soldered on PCB, the reflow profile is set according to solder paste and the thickness of PCB etc.

12.4 Rework

- (1) 250°C~270°C, maximum 30 sec, Peak temperature 330°C.
- (2) Wind speed: 15L/m.
- (3) It is very important not to put a heatgun over the acoustic port of the microphone.

13 Cautions

13.1 Board Wash Restrictions

It is very important not to wash the PCBA after reflow process, otherwise this could damage the microphone.

13.2 Nozzle Restrictions

It is very important not to be put a nozzle over the acoustic hole of the microphone, otherwise this could damage the microphone.

13.3 Blowing Restrictions

It is very important not to blow the acoustic port of the microphone directly, otherwise this could damage the microphone.

13.4 Ultrasonic Restrictions

It is very important not to use ultrasonic process. otherwise this could damage the microphone.

13.5 Case Adaption to Pressure Restrictions

It is very important not to press the case with a force larger than 2.5kgf, otherwise this would damage the microphone.

14 Output Inspection Standard

Output inspection standard is executed according to <<ISO2859-1:1999>>.